

## Object Classification using a neural networks with Gray-level Co-occurrence Matrices (GLCM).

Mehdi Ebady Manaa'  
Department of Computer  
Science  
Babylon University

Nawfal Turki Obies  
Department of Computer  
Science  
Babylon University

Dr. Tawfiq A. Al-Assadi  
Department of Computer  
Science  
Babylon University

**Abstract:** This paper describes a hybrid method in the object classification for computer digital images. method in this paper has been designed and developed to recognize a typical texture features for certain object. The basic approach used here is that the textures features values that extracted from gray level co-occurrence matrices (GLCM) can show the typical values for features analysis in classification. An artificial neural networks using error multilayer back propagation network has been used for texture analysis and object classification. The obtained results of different types of images areas like "seas" "non-seas" and "background" as unknown images was characterized in a good range.

Keyword: Object Classification, Gray-Level Co-occurrence Matrix (GLCM), Texture features.

**الخلاصة:** هذا البحث يصف طريقة هجينة لتصنيف كائن في الصور الرقمية. الطريقة صممت لتمييز صفات النسيج texture لكائن في صورة ما , حيث ان قيم صفات النسيج المستخرجة من مصفوفة حدوث المستويات الرمادية GLCM اظهرت قيم متتالية لتمييز الكائن. استخدمت الشبكة العصبية نوع انسياب الخطا خلفا ذات الطبقات المتعددة في عملية التصنيف حيث تم تدريبها على قيم الصفات المستخرجة من GLCM. النتائج المستخلصة من تدريب الشبكة لانواع مختلفة من الصورة واختيارها لصورة غير معروفة اعطت نتائج جيدة في تمييز صور البحار.

## **1. Introduction**

This paper introduces a new approach of object classification for certain type which is a part of image processing using Gray level co-occurrence matrix (GLCM) as an example the class of seas images has been used for classification and the approach can be applied for single class image in different patterns. The simplest way practice in this paper is a classification of any class images into patterns using adaptive segmentation with the use of their textures features in different direction of GLCM matrix to train the artificial neural networks (back propagation neural network used here). This association between local trained features values and recognized class sea as an example led to obtain a good results using this method [1].

Another direction in this paper is extracting the texture feature for unknown image and let the neural detect the type of this image using a neural network and the approach applied for variety images. Patterns features may be applied for realizing a wide pattern in different texture without imposing any restriction on their distribution [2]. Based on a topicality of the given approaches this paper present the texture segmentation for a new approach by using Gray level Co-occurrence Matrix (GLCM) [3].

Machine classification vision based on gray level co-occurrence matrix of class classification is necessary and important method. As it lead to obtain a good results for classification in certain features characteristics. There are different approaches in computer vision, Angelo Zizzari and Udo Seiffert used detection of tumor in digital images of the Brain[4]. Commander K.Velu [5] used an Intelligent Segmentation of Industrial Component Images. Virendra Pathak and Onkar Dikshit [6] used Segment based classification of Indian urban environment. P. Tymkow, A. Borkowski [7] introduced land cover classification using airborne laser scanning data and photographs.

When we propose a class classification based on Gray level co-occurrence matrix (GLCM) with a neural network to recognize a certain class, it is necessary to allocate following points.

- a. Choice the patterns of textures attribute for a large numbers of variety Images.
- b. adaptive Image segmentation for the input image.
- c. Texture Features extraction using GLCM Matrix in different Direction.
- d. Train a neural network on different patterns for certain class and the seas patterns used here as an example.
- d. Test unknown image by calculate the texture features by GLCM and used a neural network to detect it.

## 2. Gray Level Co-occurrence Matrix (GLCM)

A statistical approach that can well describe second-order statistics of a texture image is a co-occurrence matrix. Gray level co-occurrence matrix (GLCM) was firstly introduced by Haralick [8] [9]. A gray-level co-occurrence matrix (GLCM) is essentially a two-dimensional histogram in which the  $(i,j)$  th element is the frequency of event  $i$  co-occurs with event  $j$ . A co-occurrence matrix is specified by the relative frequencies  $P(i, j, d, \theta)$  in which two pixels, separated by distance  $d$ , occur in a direction specified by the angle  $\theta$ , one with gray level  $i$  and the other with gray level  $j$ . A co-occurrence matrix is therefore a function of distance  $r$ , angle  $\theta$  and grayscales  $i$  and  $j$ .

Our proposed system is that a sea image can be decomposed into patterns with regular textures. So we should be able to represent these regular texture regions by using co-occurrence matrices. To do so, we utilize the co-occurrence matrices in angles of  $0^\circ$ ,  $45^\circ$ ,  $90^\circ$ , and  $135^\circ$

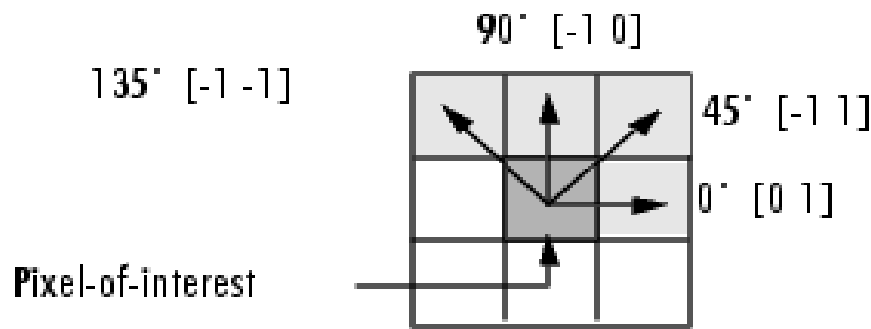

Fig.(1): Direction for generation of GLCM

After that the normalization of the obtained GLCM which refer to as  $C_d(i,j)$  has significant effect on total performance of algorithm. The problem is that the total number of compared pixels pairs is different due to the angular relationships. Moreover, the size of images is not the same. To overcome these problems, it is necessary to normalize the co-occurrence matrices using this equation [10]

$$p(m,n) = \frac{1}{All\_Pairs\_of\_Pixel\_Used} C_d(m,n)$$

## 3. Texture features

Most of the GLCM texture calculations used in remote sensing were systematized in a series of papers by Robert Haralick in the 1970's.[11], When the GLCM is generated, there are a total of 14 textures features that could be computed from the GLCM, such as contrast, variance, sum average, and etc. The five common textures features discussed here are contrast, correlation, energy, homogeneity, and

entropy. Contrast is used to measure the local variations, correlation is used to measure probability of occurrence for a pair of specific pixels, energy is also known as uniformity of ASM (angular second moment) which is the sum of squared elements from the GLCM, homogeneity is to measure the distribution of elements in the GLCM with respect to the diagonal, and entropy measures the statistical randomness. The five common textures features are shown in figure (3). Hence, 20 features or more will be extracted using GLCM methods, i.e. four directions for every feature functions of contrast, correlation, energy, entropy, and homogeneity with different spatial distance (d ) for every feature.

Energy	$\sum_{m=0}^{G-1} \sum_{n=0}^{G-1} P(m,n)^2$
Entropy	$\sum_{m=0}^{G-1} \sum_{n=0}^{G-1} p(m,n) \log p(m,n)$
Contrast	$\frac{1}{(G-1)^2} \sum_{m=0}^{G-1} \sum_{n=0}^{G-1} (m-n)^2 p(m,n)$
Correlation	$\frac{\sum_{m=0}^{G-1} \sum_{n=0}^{G-1} mnp(m,n) - \mu_x \mu_y}{\sigma_x \sigma_y}$ <p>where</p> $\mu_x = \sum_{m=0}^{G-1} m \sum_{n=0}^{G-1} p(m,n)$ $\mu_y = \sum_{n=0}^{G-1} n \sum_{m=0}^{G-1} p(m,n)$ $\sigma_x = \sum_{m=0}^{G-1} (m - \mu_x)^2 \sum_{n=0}^{G-1} p(m,n)$ $\sigma_y = \sum_{n=0}^{G-1} (n - \mu_y)^2 \sum_{m=0}^{G-1} p(m,n)$
Homogeneity	$\sum_{m=0}^{G-1} \sum_{n=0}^{G-1} \frac{p(m,n)}{(1 +  m-n )}$

Fig. (2): Textures Features equation

#### 4. Back propagation Artificial Neural Network

Back propagation, or propagation of error, is a common method of teaching artificial neural networks. It was first described by Paul Werbos in 1974, but it wasn't used until 1986, it is lead to renaissance in the field of artificial neural network research.

It is a supervised learning method, and is an implementation of the Delta rule. It requires a teacher that knows, or can calculate, the desired

output for any given input. It is most useful for feed-forward networks. The term is an abbreviation for "backwards propagation of errors". Back propagation requires that the activation function used by the artificial neurons (or "nodes") is differentiable [12].

And the Summary of the back propagation technique:

1. Present a training sample to the neural network.
2. Compare the network's output to the desired output from that sample. Calculate the error in each output neuron.
3. For each neuron, calculate what the output should have been, and a scaling factor, how much lower or higher the output must be adjusted to match the desired output. This is the local error.
4. Adjust the weights of each neuron to lower the local error.
5. Assign "blame" for the local error to neurons at the previous level, giving greater responsibility to neurons connected by stronger weights.
6. Repeat from step 3 on the neurons at the previous level, using each one's "blame" as its error.

#### 4. The Proposed System

The proposed system consists of two stages as below:-

**First Stage :** Train the neural network using textures that extracting from GLCM as illustrated in figure (4)

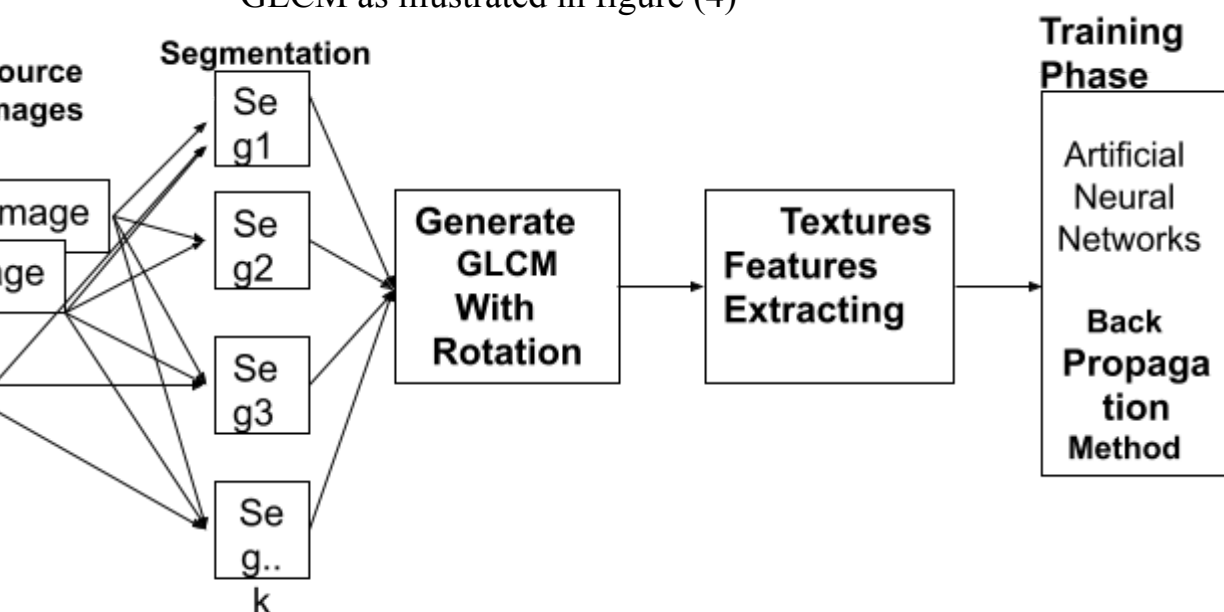
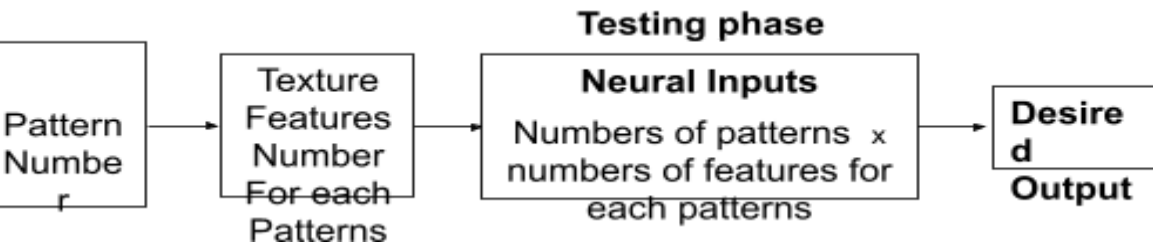

Fig. (3): Block Diagram of Training Neural Network

The Training of the Neural networks is depending on different image patterns, for each image, we perform the following:-

- a. Segment (adaptive segmentations) each image to different segments (patterns).

- b. For each segment, we calculate the GLCM method and then use it to extract textures features in different direction using the equations in Fig (3).
- c. Train the neural depending on the number of patterns and the numbers of features for each patterns as illustrated in fig (5).



**Fig. (4): testing the Neural Network using Features of GLCM**

The image which used in training the neural networks in this work is shown in Fig.(6).

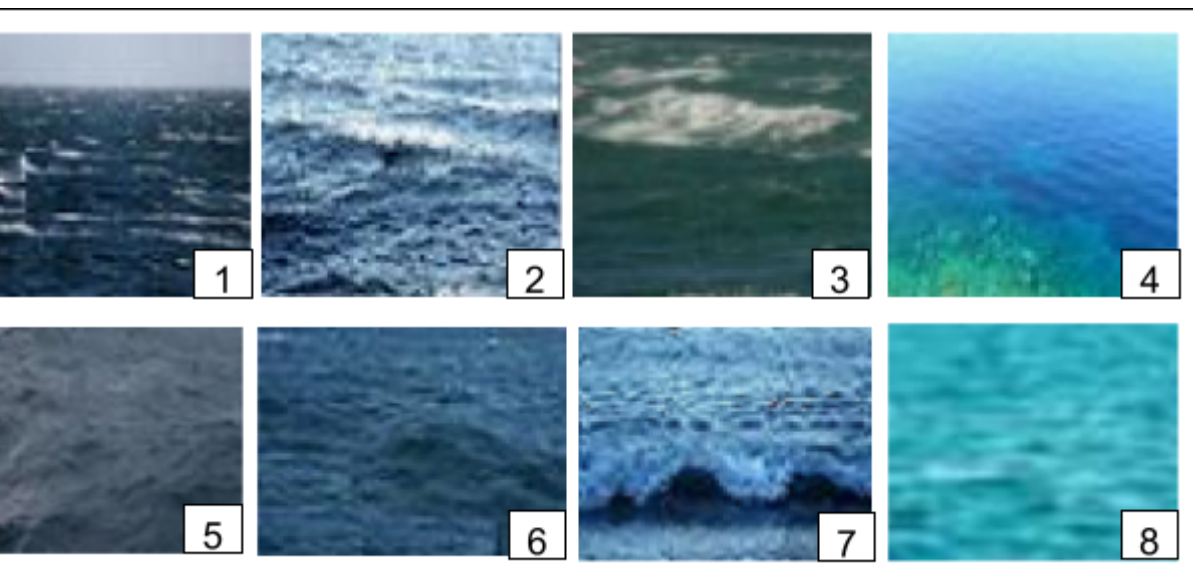

Fig. (5): images used to train a neural networks (seas images)

**Second stage:** Testing and classification

To test unknown image and classify, two steps are used, the first one is segmented the image into patterns and calculate the GLCM for each pattern. The obtained GLCM is used to extract features depending on equations which shown in figure (3).

The second step is train the above features with the desired values of Neural networks to determine the pattern belong to which pattern of sea type. The taken decision is made by a neural patterns reorganization.

The experiment are run on patterns which are not further enhanced, such as histogram equalization.

The results shows that the value differs in all spatial distances for energy, therefore the pattern of change for energy may be useful as a feature to be extracted. For the other four features, they are having closer values when the spatial distance is small, so in such case, smaller spatial distance are more suitable to be used for extraction of the features such as correlation equation.

The features for each patterns that was trained for the neural is shown in table (1) as an example after make the normalization for it.

Pattern Name	Contrast	Dissimilarity	Homogeneity	Energy	Entropy	Correlation
Pattern(1)	0.401512	0.49610	0.000356	0.000127	0.285005	0.891264
Pattern(2)	0.213672	0.28970	0.000983	0.000223	0.410021	0.983132
Pattern(3)	0.343210	0.39953	0.000309	0.000147	0.261166	0.947453
Pattern(4)	0.233556	0.33840	0.000172	0.000245	0.312132	0.963153
Pattern(k)	0.449892	0.47170	0.000872	0.000384	0.265215	0.831421

## 5. Experiments and Results

Our experiment results is determining by taken unknown image and segment it to different patterns, each pattern is passing to GLCM for extracting features. The results is checking with the features of a neural network shows that the patterns belongs to sea image and after that we take image for "non-sea" and the result was "not sea" . The answer for a neural network was evaluated by using different patterns which were submitted to the same features extraction and feature selection processes of the training sample, at the end of testing process, each image was classified as sea, not-sea. The features for each patterns that was trained for the neural is shown in table (1) as an example after make the normalization for it.

Figure (7) shows the unknown image that tested by the system which it is classified to "seas" images as it were trained previously by the neural in Fig (6) .



Fig (6): Neural networks classified these images under seas

In the other hand, Figure (7) shows the unknown image that tested by the system which it is classified to "no-seas" images according to testing of their textures features values.



Fig (7): Neural networks classified these images under "no-seas"

## 6. Conclusion

The main characteristics of such computer system are listed here from segment, feature extracting using GLCM and to neural networks, and the final results is considered satisfying by using this hybrid method that contains the previous characteristics. It has been designed and developed to recognize the typical features of certain class like the "seas" images. Regardless of segment type method that used in this paper, it is based on the concept of the texture feature for digital images Using GLCM . The data being analyzed on the images should be minimized to only the useful features value that is considered important in neural training. So the most important value was in correlation values which show that the orientation in small distance values in different viewing direction such as  $0^{\circ}$ ,  $45^{\circ}$ ,  $90^{\circ}$  and  $180^{\circ}$  is considered as a good feature extracted from the images to train the neural. When the spatial distance increases, the differences in values for different patterns (segmentation) of a same species will be more obvious for neural inputs. As an example the results for the entropy during greater spatial distances are not useful. Our efforts in this paper considered the following points to improve the performance of work:-

1. Alternative the Back propagation neural network with a modern neural networks that used for classification.
2. Discard the undesired value that extracted from GLCM method to obtain well separated data sets to train the neural.
3. Trying to recognize the target object with same homogenous values.



## References

1. Tuceryan M., Jain A.K., 1998. 'Texture Analysis. The handbook of Pattern Recognition and Computer Vision (2nd Edition)' / C.H. Chen, L.F. Pau, P.S.P. Wang (eds), World Scientific Publishing Co.. – PP. 207–248.
2. Rauf S. , Marina Luk., 2008. 'Texture segmentation of satellite images By neural networks approach', The Belarusian State University of Informatics and Radioelectronics, p. 1.
3. Materka A., StrzeleckiM., 1998. 'Texture Analysis Methods – A Review', Technical University of Lodz, Institute of Electronics, COST B11 report, Brussels.
4. Angelo Zizzari, Udo Seiffert and Bernd Michaelis, 2001. 'Detection of Tumor in Digital Images of the Brain', Institute for Electronics, Signal processing and communication, Otto-von-Guericke university –P.O Box 4120, 39016 Magdeburg. Germany. Germany.
5. Commander K.Velu and V.Selladurai, July 2007. 'Intelligent Segmentation of Industrial Component Images' , IJISE,GA,USA,ISSN:1934- 9955 ,VOL.1,NO.3, p.1.
6. Virendra Pathak and Onkar Dikshit, 2004. ' Segment based classification of Indian urban environment' , Department of Civil Engineering IIT-Kanpur, Kanpur-208016 (UP), India.
7. P. tymkow, a. borkowski, 2008. ' land cover classification using airborne laser scanning data and photographs', Department of Geodesy and Photogrammetry Wroclaw University of Environmental and Life Sciences Wroclaw, C.K. Norwida 25/27, Poland, p.1 .
8. Shapiro L.G. and Stockman G.C., 2001. 'Computer Vision', Prentice Hall, Upper Saddle River, N.J., p. 752.
9. Haralick R.M., Shanmugam K., Dinstein I., Nov 1973. 'Textural Features for Image Classification', IEEE Transactions on Systems, Man and Cybernetics.No 6. - PP. 610–621.
10. Jing Yi Tou, Phooi Yee Lau, Yong Haur Tay, ' Computer Vision-based Wood Recognition System' , Faculty of Information and Communication technology Universiti Tunku Abdul Rahman (UTAR), Malaysia
11. Haralick, R.M., 1979. 'Statistical and Structural Approaches to Texture', Proceedings of the IEEE, 67:786-804
12. [http://galaxy.agh.edu.pl/~vlsi/AI/backp\\_t\\_en/backprop.html](http://galaxy.agh.edu.pl/~vlsi/AI/backp_t_en/backprop.html)